

# A SERIES

## High Voltage Biasing Supply

The A Series of high-voltage regulated DC-DC converters addresses the needs of the miniature PCB-mount regulated high voltage power supply user. Designed and built utilizing state-of-the-art power-conversion topology, these units feature surface-mount technology and encapsulation techniques that provide high reliability and performance. Typical applications for the A Series include the following: bias supplies, electrostatic detectors, mass spectrometry, and photomultiplier tubes (PMTs).

- 8 models from 0 to 62V through 0 to 6kV
- 4, 20 or 30 watts of output power
- Maximum lout capability down to 0 Volts
- Wide input voltage range
- Available with Ripple Stripper<sup>®</sup> Filter (-F Option)
- Indefinite output short-circuit protection
- Output current monitor
- Fixed-frequency, low-stored-energy design
- >430,000 hour MTBF @65°C
- UL, cUL, CE, IEC-60950-1, and Demko Recognized



PARAMETER	CONDITIONS	MODELS																								UNITS			
<b>INPUT</b>		<b>12V</b>												<b>24V</b>															
Voltage Range	Full Power	+ 11 to 16												+ 23 to 30												VDC			
Voltage Range	Derated Power Range	+ 9 to 32												+ 9 to 32												VDC			
Current	Standby / Disable	< 30												< 30												mA			
Current	No Load, Max Eout	< 100												< 90												mA			
Current	Max Load, Max Eout	~ 400												~ 1350												mA			
AC Ripple Current	Nominal Input, Full Load	< 80												< 80												mA p-p			
<b>OUTPUT</b>		<b>1/16A</b>			<b>1/8A</b>			<b>1/4A</b>			<b>1/2A</b>			<b>1A</b>			<b>2A</b>			<b>4A</b>			<b>6A</b>						
Voltage Range	Nominal Input	0 to 62			0 to 125			0 to 250			0 to 500			0 to 1,000			0 to 2,000			0 to 4,000			0 to 6,000			VDC			
Nominal Input Voltage		12	24	24	12	24	24	12	24	24	12	24	24	12	24	24	12	24	24	12	24	24	12	24	24	VDC			
Power	Nominal Input, Max Eout	4	20	30	4	20	30	4	20	30	4	20	30	4	20	30	4	20	30	4	20	30	4	20	30	4	20	30	Watts
Current	Iout Entire Output Voltage Range	64	320	480	32	160	240	16	80	120	8	40	60	4	20	30	2	10	15	1	5	7.5	0.67	3.3	5	0.67	3.3	5	mA
Current Monitor Scaling	Full Load	0.985	3.90	7.40	438.4	1860.5	2891.5	213.3	1000	1481.5	123.1	506.3	740.7	55.56	243.9	400	31.75	129.9	211.3	16.4	66.7	85.2	12.9	48.5	56.8	12.9	48.5	56.8	mAV
Voltage Monitor Scaling	With -Y5 option	10:1 ± 2% into 10MΩ												100:1 ± 2% into 10MΩ												-			
Ripple	Full Load, Max Eout	.02	.03	.05	.013	.015	.016	.01	.04	.048	.001	.02	.017	.038	.071	.15	.01	.05	.065	.019	.057	.022	.018	.073	.112	%V p-p			
Ripple with -F-M Option*	Full Load, Max Eout, 300pF bypass Cap	.002	.004	.006	.0048	.0056	.006	.0052	.0028	.005	.001	.0138	.0016	.001	.0008	.002	.0007	.0038	.004	.0004	.0088	.0026	.0003	.0012	.004	%V p-p			
Dynamic Load Regulation	½ to Full Load, Max Eout per .1mA	<.12	<.12	<.12	<.12	<.12	<.12	<.20	<.20	<.20	<.50	<.50	<.50	<1.0	<1.0	<1.0	<2.0	<2.0	<2.0	<4.0	<4.0	<4.0	<6.0	<6.0	<6.0	V pk			
Line Regulation	Nom. Input, Max Eout, Full Power	< 0.01 %																								VDC			
Static Load Regulation	No Load to Full Load, Max Eout	< 0.01%																								VDC			
Stability	30 Min. warmup, per 8 hr/ per day	< 0.01% / < 0.02%																								VDC			
<b>PROGRAMMING &amp; CONTROLS</b>		<b>ALL TYPES</b>																											
Input Impedance	Nominal Input	+ Output Models 1.1MΩ to GND, - Output Models 1.1MΩ to +5 Vref																								MΩ			
Adjust Resistance	Typical Potentiometer Values	10K to 100K (Pot across Vref. & Signal GND, Wiper to Adjust)																								Ω			
Adjust Logic	0 to +5 for +Out, +5 to 0 for - Out	+4.64 VDC for +Output or +0.36 for -Output = Nominal Eout																								-			
Output Voltage & Impedance	T=+25°C	+ 5.00VDC ± 2%, Zout = 464Ω ± 1%																								-			
Enable/Disable		0 to +0.5 Disable, +2.4 to 32 Enable (Default = Enable)																								VDC			
<b>ENVIRONMENTAL</b>		<b>STANDARD</b>												<b>-25PPM OPTION</b>															
Operating	Full Load, Max Eout, Case Temp.	-40 to +65												+10 to +45												°C			
Coefficient	Over the Specified Temperature	±50												+25												PPM/°C			
Thermal Shock	Mil-Std 810, Method 503-4, Proc. II	-40 to +65																								°C			
Storage	Non-Operating, Case Temp.	-55 to +105																								°C			
Humidity	All Conditions, Standard Package	0 to 95% non-condensing																								-			
Altitude	Standard Package, All Conditions	Sea Level through Vacuum (Vacuum may require -P2 option, contact factory for details.)																								-			
Shock	Mil-Std-810, Method 516.5, Proc. IV	20 (Standard), 40 (-C Option)																								G's			
Vibration	Mil-Std-810, Method 514.5, Fig.14.5C-3	10 (Standard), 20 (-C Option)																								G's			

\*Note: For additional information on the reduced ripple option, see -F Option datasheet.

Specifications subject to change without notice.



Making High Voltage Easier!®

Higher Service, Higher Performance, Higher Reliability  
©2011, UltraVolt Inc. All rights reserved.

# A SERIES

## High Voltage Biasing Supply

### STANDARD CASE

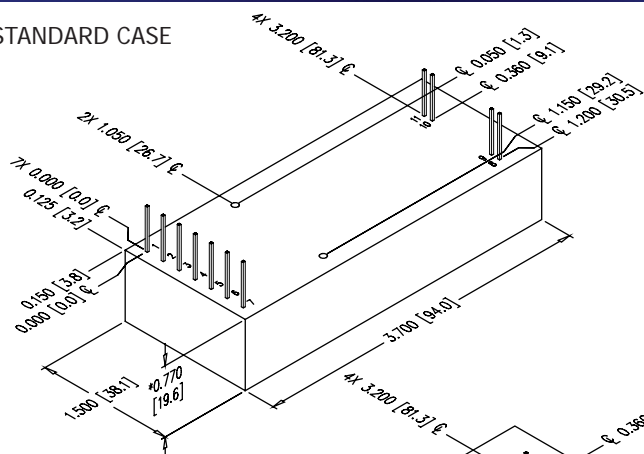

### WITH -C OPTION

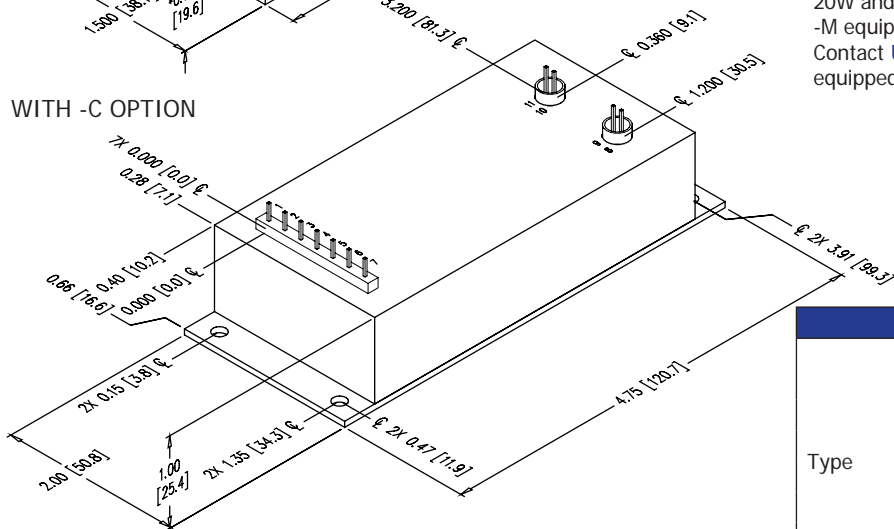

Non-RoHS compliant units are available. Please contact the factory for more information.

### CONNECTIONS

PIN	FUNCTION
1	Input-Power Ground Return
2	Positive Power Input
3	Iout Monitor
4	Enable/Disable
5	Signal Ground Return
6	Remote Adjust Input
7	+5VDC Reference Output
8	HV Ground Return
9	HV Ground Return or Eout Monitor (-Y5)
10 & 11	HV Output

All grounds joined internally. Power-supply mounting points isolated from internal grounds by >100kΩ, .01uF / 50V (Max) on all models except -M (20W and above), -M-E, -M-C, and -M-H configurations which are 0Ω.

Popular accessories ordered with this product include CONN-KIT and BR-1 mounting bracket kit.

### CONSTRUCTION

Epoxy-filled DAP box certified to ASTM-D-5948 with -C Option:  
Aluminum Alloy 5052-H32, Finish: MIL-A-8625 Type II (Anodizing)

### SIZE

Volume 4.30in<sup>3</sup> (70.5cc), w/ -C Option: 8.00in<sup>3</sup> (131.1cc)  
Weight 5.0oz (142g), w/ -C Option: 10.0oz (284g)

### TOLERANCE

Overall ±0.050" (1.27)  
Pin to Pin ±0.015" (0.38)  
Mounting hole location ±0.025" (0.64)

### NOTES

20W and 30W versions are an additional 0.062" (1.57) in height.  
-M equipped units are an additional 0.030" (0.76) for each dimension.  
Contact [UltraVolt's Customer Service Department](#) for drawings of models equipped with -E or -H options.

[Downloadable drawings \(complete with mounting & pin information\) and 3D models are available online.](#)



### ORDERING INFORMATION

Type	0 to 62 VDC Output	1/16A
	0 to 125 VDC Output	1/8A
	0 to 250 VDC Output	1/4A
	0 to 500 VDC Output	1/2A
	0 to 1,000 VDC Output	1A
	0 to 2,000 VDC Output	2A
	0 to 4,000 VDC Output	4A
	0 to 6,000 VDC Output	6A
Input	12VDC Nominal	12
	24VDC Nominal	24
Polarity	Positive Output	-P
	Negative Output	-N
Power	Watts Output (12 V Only)	4
	Watts Output (24 V Only)	20
	Watts Output (24 V Only)	30
Case	Plastic Case - Diallyl Phthalate	(Standard)
	'Eared' Chassis Mounting Plate	-E
	RF-Tight Aluminum Case	-C
Heat Sink	.400" High (sized to fit case)	-H
Ripple Stripper®	Integral Output Filter*	-F
Shield	Six-sided Mu-Metal Shield	-M
Voltage Monitor	Optional Eout Monitor	-Y5
Iout Monitor Boost	Boosted Iout Monitor Signal Level	-Y10
Temp. Coefficient	25PPM Temperature Coefficient	-25PPM

\*Note: For additional information on the reduced ripple option, see [-F Option datasheet](#).

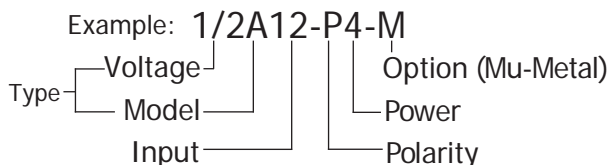

Rev. AB 9/11



Making High Voltage Easier!®

1800 Ocean Avenue, Ronkonkoma, NY 11779  
Phone: 1-631-471-4444 Fax: 1-631-471-4696 [www.ultravolt.com](http://www.ultravolt.com)