

# EFL SERIES

## Enhanced Floating Hot Deck LVPS With Isolated Digital and Analog I/O

The EFL Series of floating-hot-deck, low-voltage power supplies offers an integrated solution for systems requiring LV power & controls with high-voltage isolation. Combining a highly isolated, DC-to-DC, multi-output low-voltage power supply (LVPS) with an advanced isolated digital & analog I/O topology, the EFL sub-system provides both power and controls to floating-hot-deck circuitry. This solution, when combined with one or more UV HVPS or other circuitry, can provide high-performance solutions for applications such as:



- |                                       |                             |
|---------------------------------------|-----------------------------|
| Floating/Stacked Ion or E-Beam Biases | Floating Filament Bias      |
| Floating Pulsers & Gated Grids        | Floating Capacitance Meters |
| Floating High Side Current Monitors   | Floating Leakage Testers    |

- Precision analog control
- Linearity of  $\pm 0.05\%$  and accuracy of  $\pm 0.2\%$
- 10ppm temperature coefficient
- Isolated up to 15kV
- DC leakage current of  $< 10\text{nA}$
- 4 regulated floating LV power outputs
- Isolated digital and analog I/O to and from floating hot deck

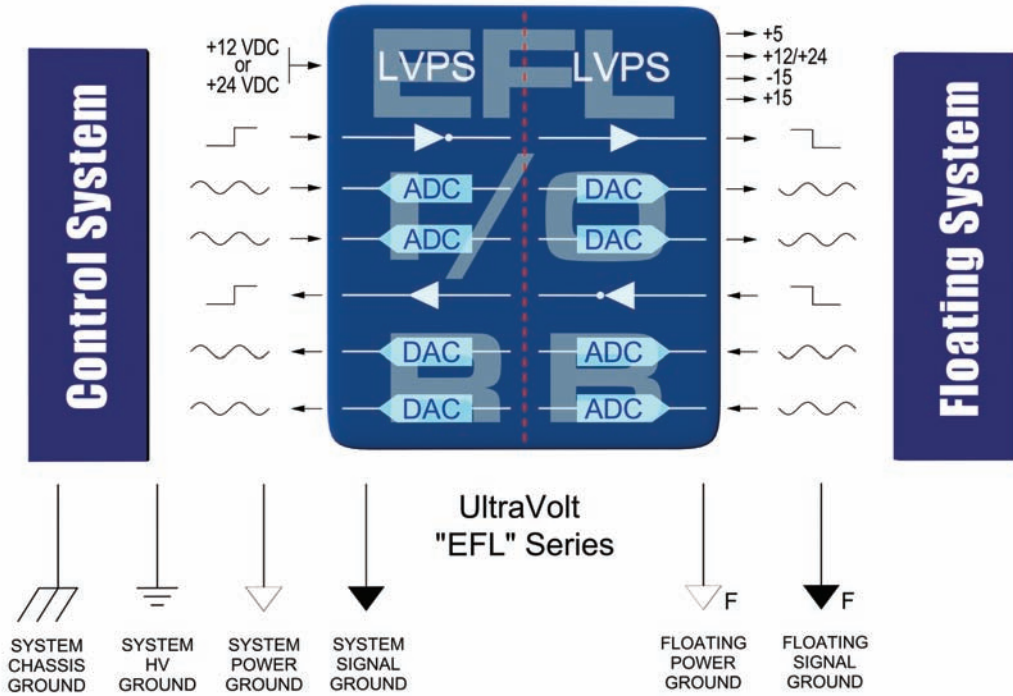

### NORMAL, HALF QUIET, AND QUIET MODES:

All EFLs feature a mode control. Three different models, Normal, Half-Quiet, and Quiet, are selectable via the voltage level at the mode pin. A voltage between -1.0V and +0.8V keeps the unit in Normal mode; the up and down analog channels follow their inputs. If the mode feature is not used, the mode pin must be grounded for the EFL to operate properly.

A voltage more negative than -4.00V places the EFL in Half-Quiet mode. The up channels do not respond to changes in their inputs in Half-Quiet mode.

A voltage greater than +3.75V and less than +5.0V places the EFL in Quiet mode. In Quiet mode, the up and down channels do not respond to changes in their inputs.

The voltage level at the mode pin must not exceed +5.0V at any time. Please contact UltraVolt's customer service department for an analysis of your requirements.

Note: If a voltage  $> 0.8\text{V}$  is applied to the mode pin, it must source less than 400uA.

Specifications subject to change without notice.



Making High Voltage Easier!®

Higher Service, Higher Performance, Higher Reliability  
©2011, UltraVolt Inc. All rights reserved.

# EFL SERIES

## Enhanced Floating Hot Deck LVPS With Isolated Digital and Analog I/O

PARAMETER	CONDITIONS	MODELS			UNITS
INPUT POWER		12W MODELS	24W MODELS	36W MODELS	
Voltage Range	Full Power	+12 ± 5%	+24 ± 10%	+24 ± 10%	VDC
Current	Standby ( Disabled )	< 150	< 100	< 100	mA
Current	No Load	< 0.50	< 0.50	< 0.50	A
Current	Max Load	< 2.50	< 2.30	< 3.00	A
AC Ripple Current	Nominal Input, Full Load	< 50	< 50	< 50	mA p-p
LOCAL CONTROLS: REFERENCE		ALL TYPES			
Output Voltage	T = +25°C, Initial value	+5.1 ± 2%			VDC
Output Impedance	T = +25°C	464 ± 1%			Ω
Stability	Over full temperature range	0.4			mV/°C
LOCAL CONTROLS: LVPS ENABLE / DISABLE		ALL TYPES			
Power supply on	Open, or a voltage above TTL high (Isource <400uA)	+3.2 to 5			VDC
Power supply off	Grounded, or a voltage below TTL low	< 0.8 (Isink 1mA minimum)			VDC
INPUT / OUTPUT ISOLATION:		ALL TYPES			
Isolation Voltage	Continuous	15			kV
Leakage Current	All inputs to all outputs	< 10			nA
Leakage Capacitance	All inputs to all outputs	< 40 std, < 50 "-E"			pF
ISOLATED POWER OUTPUTS:		15EFL12-12W	15EFL24-24W	15EFL24-36W	
Output #1 Power	Nominal input, max lout	12	24	36	W
Output #1 Voltage	Nominal input voltage range	+12 ± 2%	+24 ± 2%	+24 ± 2%	VDC
Output #1 Current	Minimum to Maximum	0 to 1	0 to 1	0 to 1.5	A
Output #1 Line Regulation	Nominal input range, full load	< 0.1 %	< 0.1 %	< 0.1 %	VDC
Output #1 Load Regulation	No load to full load	< 0.25 %	< 0.30 %	< 0.40 %	VDC
Output #1 Ripple	Full load	< 2.5 %	< 1.5 %	< 1.5 %	V p-p
Output #2 & #4 Voltage	Nominal input voltage range	±15 ± 5 %	±15 ± 5 %	±15 ± 5 %	VDC
Output #2 & #4 Current	Minimum to Maximum	0 to 50	0 to 50	0 to 50	mA
Output #2 & #4 Line Regulation	Nominal input range, full load	< 0.3 %	< 0.3 %	< 0.3 %	VDC
Output #2 & #4 Load Regulation	No load to full load	< 5 %	< 1 %	< 1 %	VDC
Output #2 & #4 Ripple	Full load	< 2.5 %	< 2.5 %	< 2.5 %	V p-p
Output #3 Voltage	Nominal input voltage range	+5.1 ± 1%	+5.1 ± 1%	+5.1 ± 1%	VDC
Output #3 Current	Minimum to Maximum	500	500	500	mA
Output #3 Line Regulation	Nominal input range, full load	< 1 %	< 1 %	< 1 %	VDC
Output #3 Load Regulation	No load to full load	< 1 %	< 1 %	< 1 %	VDC
Output #3 Ripple	Full load	< 4 %	< 4 %	< 4 %	V p-p
ISOLATED CONTROLS: TTL CHANNEL "UP"		ALL TYPES			
Local input	Source voltage, sink current	0 ≤ 0.5 (Isink 3mA minimum) 1 ≥ 2.4 (300uA max or open collector)			VDC
Isolated output	Inverted & buffered TTL	1 ≥ 2.4, 0 ≤ 0.55 ± (Sources 0.8 mA, Sinks 3 mA)			VDC
Baud Rate	Duty cycle	< 15			ms
ISOLATED CONTROLS: ANALOG CHANNEL "UP"*		12V MODELS	24V MODELS		
Local input voltage	Range	0 to + 5	0 to + 10		VDC
Isolated output voltage	Range	0 to + 5	0 to + 10		VDC
Local input impedance		20.0 K			Ω
Initial offset error		< ± 2			mV
Gain error	Full scale	< ± 0.2 %			VDC
Linearity error	Full scale	< ± 0.05 %			VDC
Stability	30 min. warm-up, per 8 hrs / per day	< 0.02%			VDC
Temperature Coefficient	0 to +55 °C	< ± 10			ppm/°C
Bandwidth	Symmetric or asymmetric signal	DC to 4			Hz

\*Note: Analog Channel UP parameters are valid for outputs in the range of 10% to 100% of maximum.



Making High Voltage Easier!®

1800 Ocean Avenue, Ronkonkoma, NY 11779  
Phone: 1-631-471-4444 Fax: 1-631-471-4696 www.ultravolt.com

# EFL SERIES

Enhanced Floating Hot Deck LVPS With Isolated Digital and Analog I/O

'-RB' ISOLATED CONTROLS: TTL CHANNEL "DOWN"			
PARAMETER	CONDITIONS	ALL TYPES	UNITS
Isolated 'Hot Deck' Input	Source voltage, sink current	0 ≤ 0.5 (Isink 1mA Minimum) 1 ≥ 2.4 (300uA max or open collector)	VDC
Local output	Inverted & Buffered TTL	1 > 2.4 (Sources 0.8mA) 0 < 0.55 (Sinks 10mA)	VDC
Propagation Delay	Duty cycle	< 15	ms
ISOLATED CONTROLS: ANALOG CHANNELS #1 & #2 "DOWN" **			
PARAMETER	CONDITIONS	ALL TYPES	UNITS
Isolated 'Hot Deck' +Input	Range	0 to +5 for 12V and 0 to +10 for 24V	VDC
Isolated 'Hot Deck' -Input	Range	0 to -5 for 12V and 0 to -10 for 24V	VDC
Isolated 'Hot Deck' + or - Input impedance	Signal source	> 10	MΩ
Local output +voltage	Range	0 to +5 for 12V and 0 to +10 for 24V	VDC
Local output -voltage	Range	0 to -5 for 12V and 0 to -10 for 24V	VDC
Initial offset error	Signal source	< ± 2	mVDC
Gain error	Full scale	< ± .2%	VDC
Linearity error	Full scale	< ± .05%	VDC
Stability	30 min. warm-up, per 8 hrs / per day	< 0.01% / < 0.02%	VDC
Temperature Coefficient	-20 °C to +55 °C	< ± 10	ppm/°C
Bandwidth	Symmetric or asymmetric signal	DC to 4	Hz
TEMPERATURE:			
	CONDITIONS	ALL TYPES	
Operating	Full load, case measurement	-20 to +55	°C
Storage	Non-operating, case measurement	-55 to +85	°C
Thermal shock	Mil-Std-810, Method 503-4, Proc. II	-20 to +55	°C
ALTITUDE:			
		ALL TYPES	
Operating	All operating conditions	Sea level to Vacuum	
Storage	Non-operating	Sea level to Vacuum	
SHOCK & VIBRATION:			
		ALL TYPES	
Shock	Mil-Std-810, Method 516.5, Proc IV	20	G's
Vibration	Mil-Std-810, Method 514.5, Fig. 514.5C-3	10	G's

\*\*Note: Analog Channels #1 & #2 DOWN parameters are valid for outputs in the range of 10% to 100% of maximum.



Making High Voltage Easier.®

1800 Ocean Avenue, Ronkonkoma, NY 11779  
Phone: 1-631-471-4444 Fax: 1-631-471-4696 www.ultravolt.com

# EFL SERIES

Enhanced Floating Hot Deck LVPS With Isolated Digital and Analog I/O

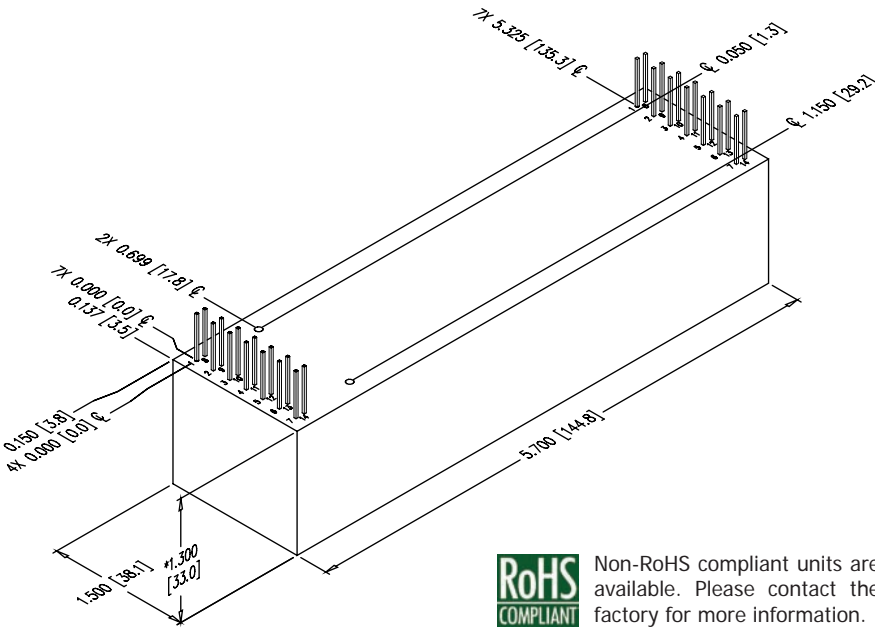

**RoHS COMPLIANT** Non-RoHS compliant units are available. Please contact the factory for more information.

### CONSTRUCTION

Epoxy-filled DAP box certified to ASTM-D-5948

### SIZE

Volume:  
All Types: 11.1 in<sup>3</sup> (182cc)

Weight:  
All Types: 13.3 oz (377.1g)

### TOLERANCE

Overall ±0.050" (1.27)  
Pin to Pin ±0.015" (0.38)  
Mounting hole locations ±0.025" (0.64)

### NOTES

24-watt and 36-watt versions are an additional 0.062" (1.57) in height.  
-M equipped units are an additional 0.030" (0.76) in height.  
Contact UV Customer Service for drawings of models equipped with -E options.

[Downloadable drawings \(complete with mounting & pin information\) and 3D models are available online.](#)

LOCAL CONNECTIONS	
PIN	FUNCTION
1	Input Power Ground Return
2	Positive Power Input
3	LVPS Enable/Disable/Sync In
4	TTL Up
5	Signal Ground Return
6	Analog Up Channel 1
7	+5V Reference Output
8	Analog Down Channel 1, +
9	Analog Down Channel 1, -
10	Analog Down Channel 2, +
11	Analog Down Channel 2, -
12	Analog Up Channel 2
13	Mode
14	TTL Output (Inverted Digital Down Channel 1)

ISOLATED/FLOATING CONNECTIONS	
PIN	FUNCTION
1	Analog Down Channel 1, +
2	Analog Down Channel 1, -
3	Analog Down Channel 2, +
4	Analog Down Channel 2, -
5	+15VDC Output
6	Analog Up Channel 2
7	Floating TTL input (Digital Down Channel 1)
8	Floating PWR Ground Return
9	Floating +12VDC or +24VDC Output
10	Floating -15VDC Output
11	Floating TTL Up
12	Floating Signal Ground Return
13	Floating Analog Up Channel 1
14	Floating +5.1VDC Reference Output

ORDERING INFORMATION		
Type	15kV Isolation	15EFL
Input Voltage	12VDC Nominal	12
	24VDC Nominal	24
Power	Watts Output (12Vin Only)	-12W
	Watts Output (24Vin Only)	-24W
	Watts Output (24Vin Only)	-36W
Standard	(1) Digital Up Channel & (2) Analog Up Channels	-I/O
Features	(1) Digital Down Channel & (2) Analog Down Channels	-R/B
Options	Partial Mu-Metal Shield	-M
Case	Plastic Case - Diallyl Phthalate	Standard
	'Eared' Chassis Mounting Plate	-E

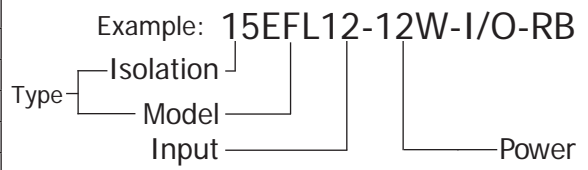

Rev. E 9/11



Making High Voltage Easier!®

1800 Ocean Avenue, Ronkonkoma, NY 11779  
Phone: 1-631-471-4444 Fax: 1-631-471-4696 www.ultravolt.com