

FIL SERIES

Precision Filament Supply

The FIL Series is a non-isolated precision filament supply. This line of regulated DC-DC converters addresses the needs of the high precision and high stability power supply user. Designed and built utilizing a state-of-the-art power-conversion topology, these units feature surface-mount technology and encapsulation techniques that provide high reliability and low cost. The FIL Series supply allows users to properly operate the filament to maximize performance and extend its life. [Typical applications](#) for this series include precision filaments for mass spectrometry, electron beams, and test equipment.



- High precision and high stability
- 15PPM temperature coefficient
- 0 to 5VDC
- 0 to 3 Amps of current
- Maximum Iout capability down to 0 Volts
- Programmable voltage and current controls

- Indefinite output short-circuit protection
- Buffered output current & voltage monitors
- Excellent linearity & accuracy of control
- Current mode and voltage mode indicator
- Synchronizable

PARAMETER	CONDITIONS	MODELS	UNITS
INPUT		ALL TYPES	
Operating Range	All Conditions	+24 ± 10	VDC
Current	Full Load Output	900mA Typical	mA
OUTPUT		ALL TYPES	
Voltage Range	Nominal Input	0 to 5	VDC
DC Current Range	Nominal Input	0 to 3	Amps
Voltage Range	Derated	0 to 5.7	VDC
DC Current Range	Derated	0 to 3.3	Amps
Voltage Monitor Scaling	Full Load	10	VDC
Current Monitor Scaling	Full Load	10	VDC
PROGRAMMING & CONTROLS		ALL TYPES	
Input Impedance	Nominal Input	+ Output Models 10MΩ to GND	MΩ
Adjust Resistance	Typical Potentiometer Values	10K to 100K (Pot across Vref. & Signal GND, Wiper to Adjust)	Ω
Adjust Voltage	Referenced to signal ground	0 to +10 VDC	VDC
Accuracy	In current control	±0.1%	Amps
Offset	Voltage control	0.04%	VDC
Offset	Current control	0.001%	Amps
Output Voltage	T=+25°C, Initial Value	+10.0V ± 0.05%	VDC
Enable/Disable		0 to +0.5 Disable, +2.4 to 10 Enable (Default = Enable)	VDC
ENVIRONMENTAL		ALL TYPES	
Operating	Full Load, Max Eout, Case Temp.	+10 to +45	°C
Coefficient	Over the Specified Temperature	≤ 15	PPM/°C
Thermal Shock	Mil-Std 810, Method 503-4, Proc. II	-40 to +65	°C
Storage	Non-Operating, Case Temp.	-55 to +85	°C
Altitude	Standard Package, All Conditions	Sea Level through Vacuum	-
Shock	Mil-Std-810, Method 516.5, Proc. IV	20	G's
Vibration	Mil-Std-810, Method 514.5, Fig.514.5C-3	10	G's

Specifications subject to change without notice.



Making High Voltage Easier!®

Higher Service, Higher Performance, Higher Reliability

©2011, UltraVolt Inc. All rights reserved.

FIL SERIES

Precision Filament Supply

INPUT/OUTPUT WIRING DIAGRAM

The filament power supply load should be connected between the FIL(+) output and the FIL(-) output, load current should not flow through the center tap, which is common with the (+)24V return. The FIL(-) or FIL(+) outputs should not be grounded.

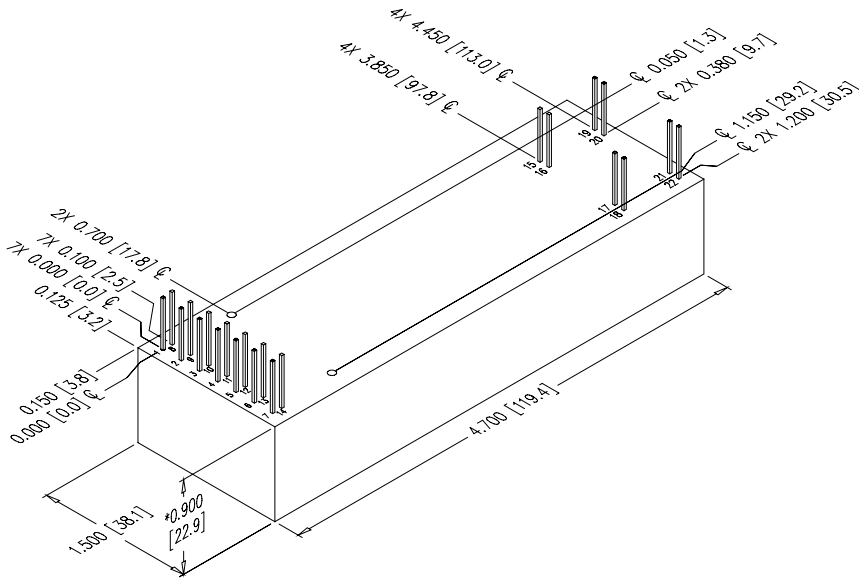
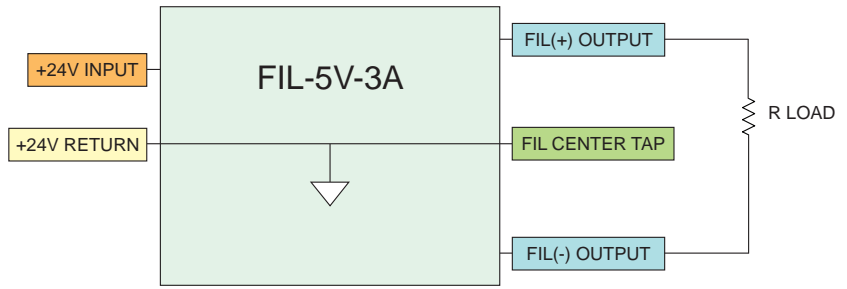

CONSTRUCTION

Epoxy-filled DAP box certified to ASTM-D-5948

SIZE

Volume:
6.35 in³ (104cc)
Weight:
6.75 oz (191g)

TOLERANCE

Overall ±0.050" (1.27)
Pin to Pin ±0.015" (0.38)
Mounting hole locations ±0.025" (0.64)

NOTES

-M equipped units are an additional 0.030" (0.76) in height. Contact UV Customer Service for drawings of models equipped with -E or -H options.

[Downloadable drawings \(complete with mounting & pin information\) and 3D models are available online.](#)

CONNECTIONS	
PIN	FUNCTION
1 & 8	Input-Power Ground
2 & 9	Positive Power Input
3	Iout Monitor
4	Enable/Disable
5	Signal Ground
6	Voltage Programming
7	+10.0V Reference Output
10	Sync In
11	I mode Indicator
12	V mode Indicator
13	Current Programming
14, 17, & 18	Vout Monitor
15 & 16	Fil Output (-)
19 & 20	Fil Output (+)
21 & 22	Center Tap

All grounds joined internally.



Non-RoHS compliant units are available. Please contact the factory for more information.

ORDERING INFORMATION		
Type	0 to 5 VDC Output	FIL-5V
Current	Current Output (0 to 3A)	-3A
Case	'Eared' Chassis Mounting Plate	-E
Heat Sink	.400" High (sized to fit case)	-H
Shield	Six-sided Mu-Metal Shield	-M

Example: **FIL-5V-3A-M**



Rev. D 9/11



Making High Voltage Easier!®

1800 Ocean Avenue, Ronkonkoma, NY 11779
Phone: 1-631-471-4444 Fax: 1-631-471-4696 www.ultravolt.com